

Tracing the Skyline

Dr. Matt Tomkins

Task

Using a compass (used for measuring horizontal angles) and Abney level (used for measuring vertical angles), estimate the elevations of the mountains surrounding Keswick.

Context

Mountains hold special scientific, cultural, and economic significance. Throughout history, they have been used to demarcate the boundaries between regions. More recently, **triangulation** from mountain summits has allowed us to estimate the size and dimensions of countries with much greater accuracy and precision e.g. the Principal Triangulation of Great Britain (1791 – 1853), as shown below:

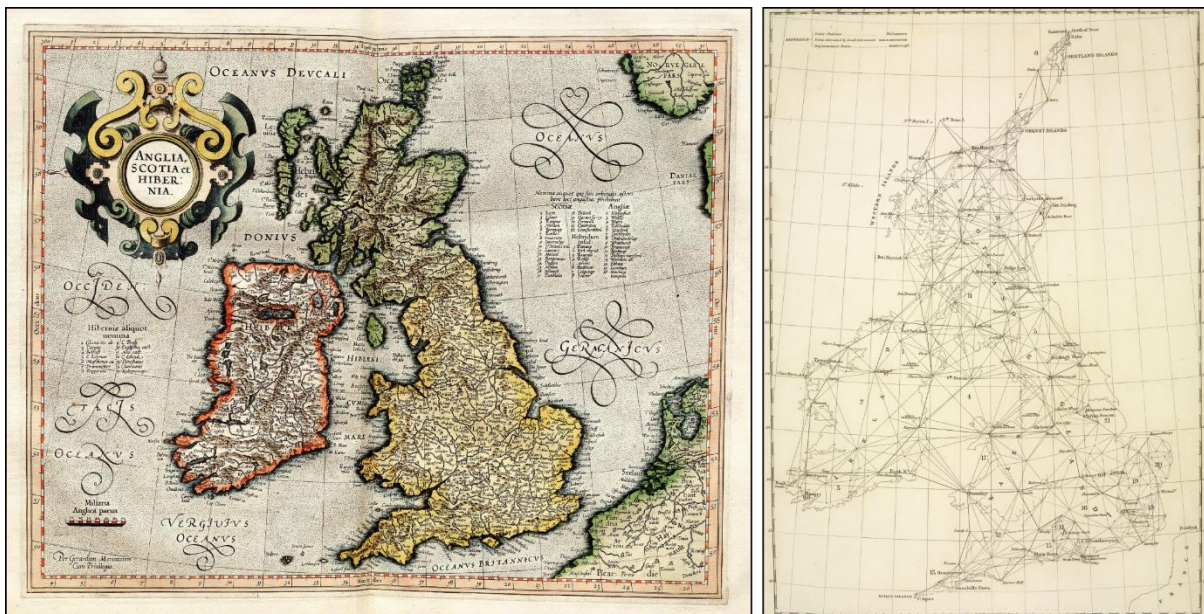

Figure 1: Maps of Great Britain and Ireland before triangulation (**left:** Atlas Cosmographicae by Gerardus Mercator, 1512 – 1594) and after triangulation (**right:** Principal Triangulation of Britain, 1791 – 1853). While triangulation was used for local mapmaking prior to this date, with the earliest evidence for the technique dating to ~1000 AD, this was the first attempt to apply the technique to an entire country.

While mountains, coastlines and land areas are measured today using GPS and satellites, triangulation is still used for many purposes, including surveying, navigation, metrology etc. It is also an important component of **Geographic Information Science (GIS)**.

Finding the distance to objects

We can calculate the height of distant objects using **trigonometry**.

However, we first need to know the distance to them. This can be achieved by measuring the horizontal angles to that object from two (or more) other measurement points.

For example, let's say we are in particular location (we'll call it **Point A**) and are interested in feature of the landscape (e.g. a mountain, Peak I), but do not know how far away it is or its elevation:



If we can see that same feature from a different location (as shown below, **Point B**), then we can estimate the distance to the unknown point (and in future, it's height) with only a few simple measurements using a compass (horizontal angles) and an Abney level (vertical angles):



The theory

If we know the distance between our locations, we could sketch out a birds-eye view of the landscape:

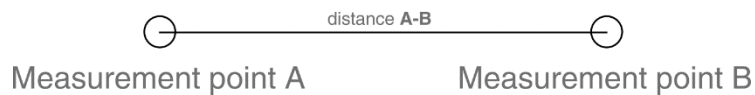

Our first step is to measure the horizontal angles from A and B to the measurement point using a compass. The final angle of the triangle (Angle **C**) equals $180 - \text{Angle A} - \text{Angle B}$, because the interior angles of a triangle = 180° .

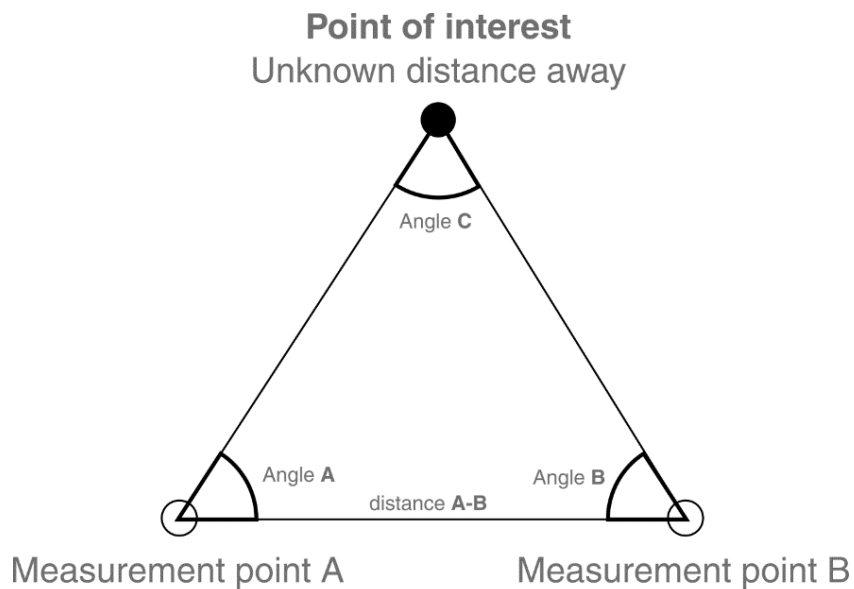

Using this information, the distances between A-C and B-C can be calculated using the trigonometric formulas shown below:

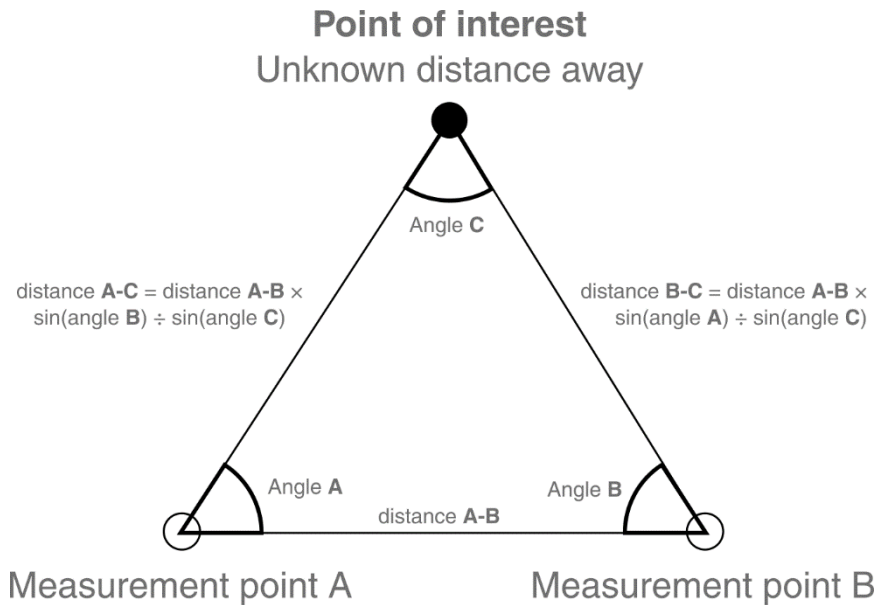

Lots of maths here, but **don't be alarmed**.

Finding the height of objects

Once we know the distance to an object, finding its height is comparatively easy. This involves measuring the vertical angle to it (using the Abney level) and using the following formula:

$$\text{Height} = \text{distance} \times \tan(\text{angle}) + \text{elevation of the observer}$$

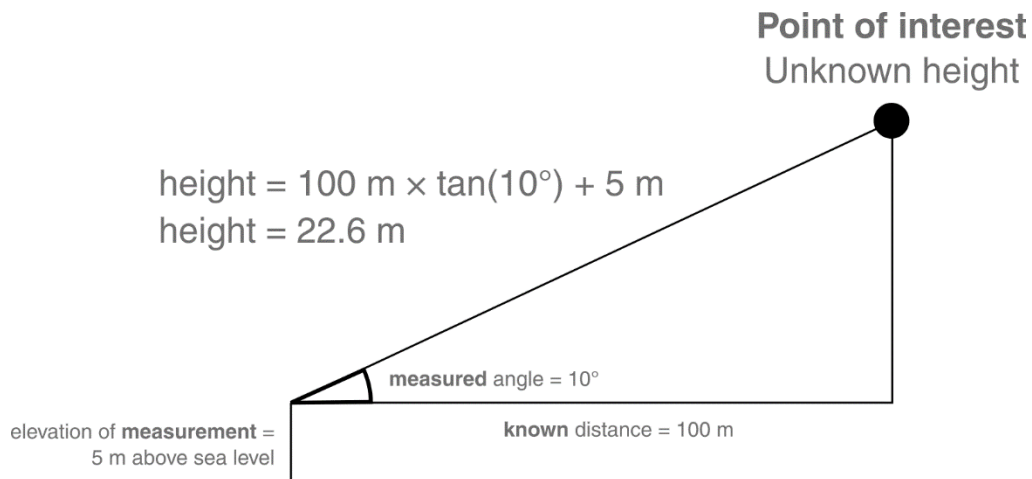

An example: Peak I

Here are measurements for Peak I. The distance between Point A and Point B was 847 m, and the **horizontal angles** to Peak I were 48° and 123° respectively¹, which gives us the following birds-eye view:

NOT DRAWN TO SCALE

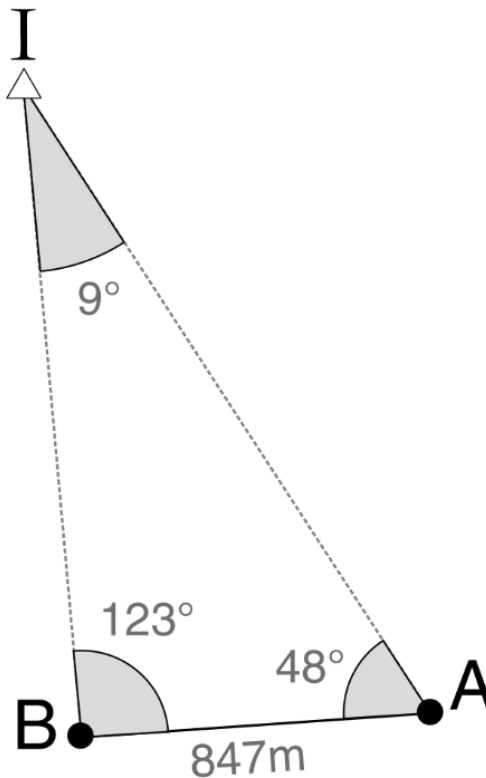

Using the **distance** formulas shown on p.4, we can now work out the length of the sides:

$$\text{Side A-I} = 847 \text{ m} \times \sin(123) \div \sin(9) = \underline{\hspace{2cm}} \text{ m}$$

$$\text{Side B-I} = 847 \text{ m} \times \sin(48) \div \sin(9) = \underline{\hspace{2cm}} \text{ m}$$

¹ I've missed talking about a key step here (for simplicity) which involves converting compass measurements to the interior angles of a triangle. **Q:** Why is this step needed?

I also measured the **vertical angle** to Peak I from both locations. This was approximately 5° from Point A and 6° from Point B:

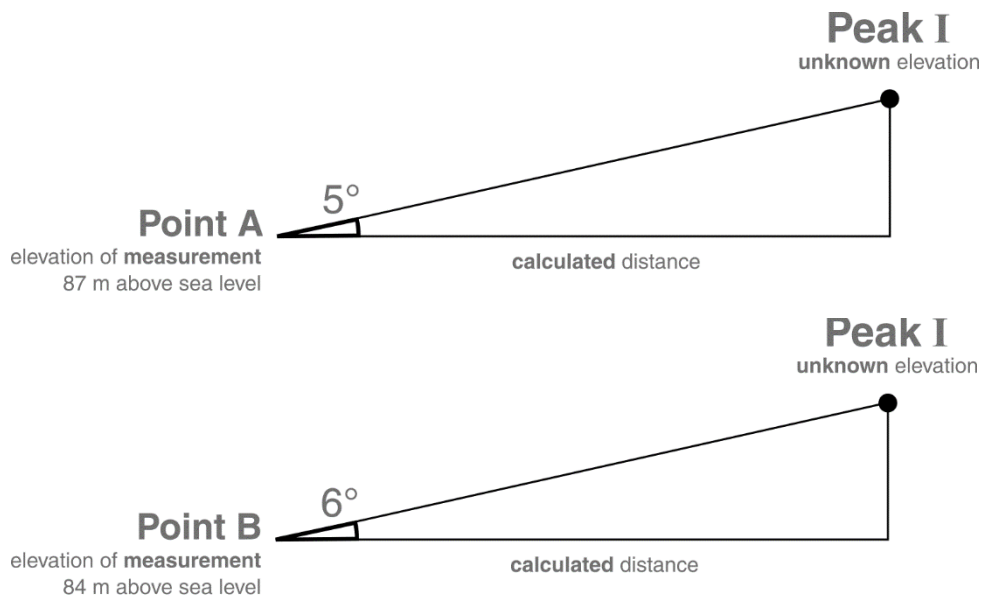

Using the **height** formulas shown on p.4, we can now work out the height of peak I, remembering to add on the elevations of the measurement points!

$$\text{Height I (from A)} = \text{_____ m} \times \tan(5) + 87 \text{ m} = \text{_____ m}$$

$$\text{Height I (from B)} = \text{_____ m} \times \tan(6) + 84 \text{ m} = \text{_____ m}$$

Result:

The actual recorded height of the mountain is **502 m**, so we're off by approximately _____ m and _____ m respectively.

Q: Would you consider this to be a good result?

Q: What are the limitations of our approach?

Q: How could these be addressed?

Putting theory into practice

With all this information at your disposal, your **task for today** is to visit locations in Keswick and use a mirror compass and Abney level to estimate the elevations of the surrounding mountains.

Measurement points are denoted as **A** and **B** and are shown on the map on the following page. You will be given a GPS to locate the exact locations.

At each point, you'll need to measure the directions (compass) and vertical angles (Abney level) to nearby mountain summits. These are numbered **II**, **III** and **IV**:

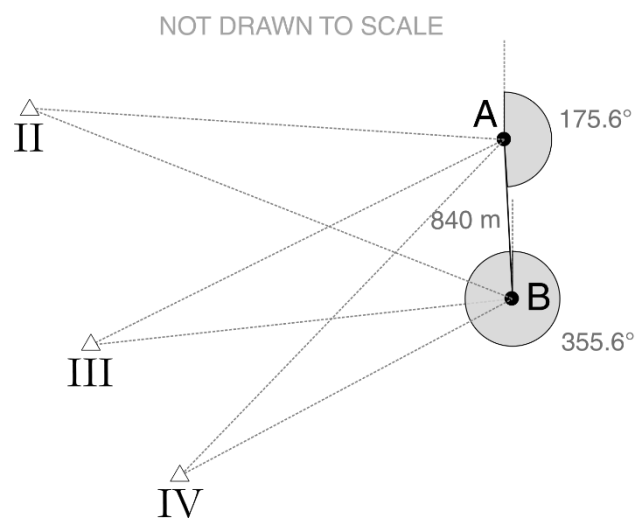

Each group should have multiple compasses and Abney levels, so take the opportunity to collect a number of measurements as a group to find the correct value. Try to be as precise as possible.

Viewpoint locations: Keswick



Point A 54.59747, -3.14189, 96 m a.s.l

Point B 54.58995, -3.14089, 85 m a.s.l

Point A (Crow Park)

54.59747, -3.14189, 96 m

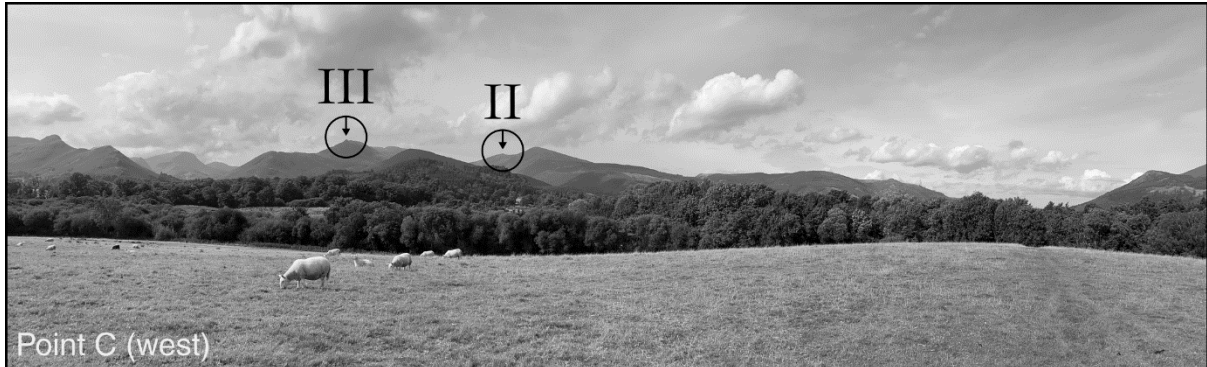

At Point A, take measurements for Peaks II, III and IV:

Direction ($^{\circ}$) to Peak II =

Vertical angle ($^{\circ}$) to Peak II =

Direction ($^{\circ}$) to Peak III =

Vertical angle ($^{\circ}$) to Peak III =

Direction ($^{\circ}$) to Peak IV =

Vertical angle ($^{\circ}$) to Peak IV =

Point B (Friar's Crag)

54.58995, -3.14089, 85 m



At Point B, take measurements for Peaks II, III and IV:

Direction ($^{\circ}$) to Peak II =

Vertical angle ($^{\circ}$) to Peak II =

Direction ($^{\circ}$) to Peak III =

Vertical angle ($^{\circ}$) to Peak III =

Direction ($^{\circ}$) to Peak IV =

Vertical angle ($^{\circ}$) to Peak IV =

Calculations

To simplify the calculations for you (and to save you all from having to relieve the trauma of trigonometry), I've done this for you on Google Sheets, with a separate sheet for each group:

Group 1



<https://tinyurl.com/tracing-group-1>

Group 2



<https://tinyurl.com/tracing-group-2>

Group 3



<https://tinyurl.com/tracing-group-3>

Group 4



<https://tinyurl.com/tracing-group-4>

All there is for you to do is add your measurements on the **Inputs** tab, and see the output summit elevations on the **Results** tab.

Competition

You will be in groups of 3 – 4. When you've completed your measurements, you should be able to estimate the elevations of peaks II, III and IV with some accuracy using the Google sheet formulas. The group which gets closest to the true elevation of each peak will be the winner (**prizes will be awarded**).